

**TCXO**



**4 Pad Version 3.2×2.5 mm**

- ±0.5~±2.5 ppm stability
- Ultra-miniature package
- Clipped sine wave
- Low power consumption
- Reflow soldering temperature: 260°C max



RoHS compliant

**★ PARAMETERS**

PARAMETERS	SPECIFICATION	
Frequency Range	10.0~52.0MHz	
Supply Voltage	1.8V、2.5V、2.8V、3.3V	
Supply Current	13MHz≤F0≤26MHz: 1.5mA max 26MHz<F0≤52MHz: 2.0mA max	
Frequency Tolerance	±1.0ppm、±1.5ppm、±2.0ppm	
Frequency Stability	Vs Temperature (ref. to +25°C)	±0.5~±2.5ppm
	Vs Supply voltage change (±5%)	±0.2ppm
	Vs Load change (±10%)	±0.2ppm
	Vs Aging (1 <sup>st</sup> Year ,25±2°C)	±1.0ppm
Operating Temp. Range	-30~+85°C、-40~+85°C	
Storage Temp. Range	-55~+125°C	
Output Waveform:	Clipped Sine Wave	
Output Level:	0.8 Vp-p Min (Clipped Sine Wave)	
Output Load	10KΩ/10pF	
Symmetry	45% ~ 55% typ.	
Start-up Time	2.0mS max	
Phase Noise	-115 dBc/Hz max @100Hz offset	
	-135 dBc/Hz max @1KHz offset	
	-148 dBc/Hz max @10KHz offset	

⊙ All specification subject change without notice.

**★ DIMENSIONS& LAND PATTERN LAYOUT (Unit: mm)**

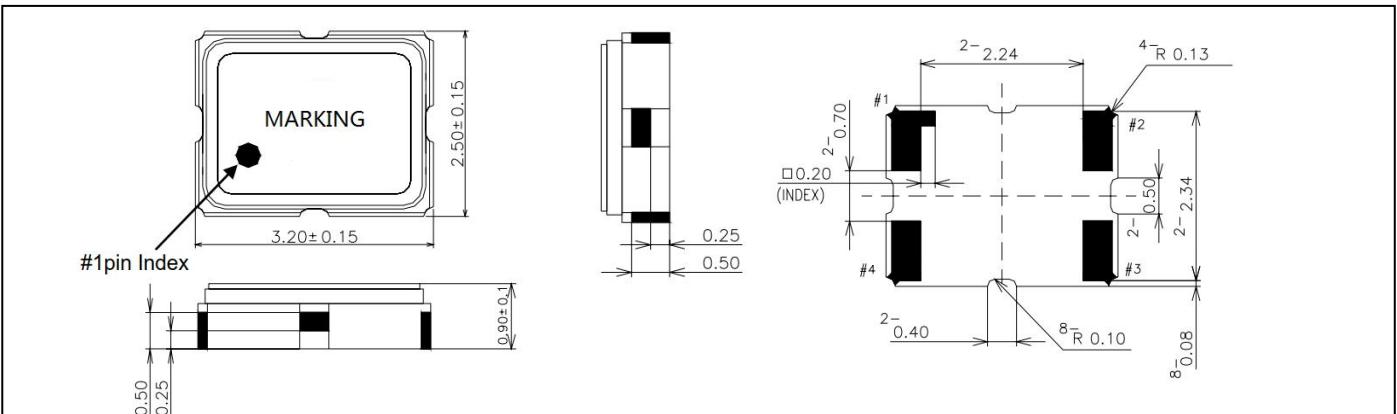

**★ PART NUMBER GUIDE** e.g. FTO26.000M3.0SM3-1.0/2.5C (\*SM3=3.2×2.5 SMD TYPE)

Logo	TCXO	Frequency	Supply voltage V <sub>DD</sub>	Package	Frequency Tolerance ppm	Frequency Stability ppm	Operating Temp.
F	TO	26.000M	3.0	SM3	1.0	2.5	C

Definition	Description	
Operating Temperature Range	<b>A:</b> -10~+60°C	<b>B:</b> -20~+70°C
	<b>C:</b> -30~+80°C	<b>D:</b> -40~+85°C
	<b>S:</b> Customer specified	

★ TEST CIRCUIT

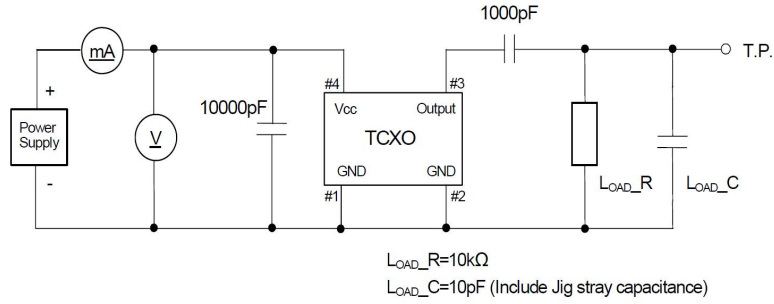

★ TAPING SPECIFICATION (Unit: mm)

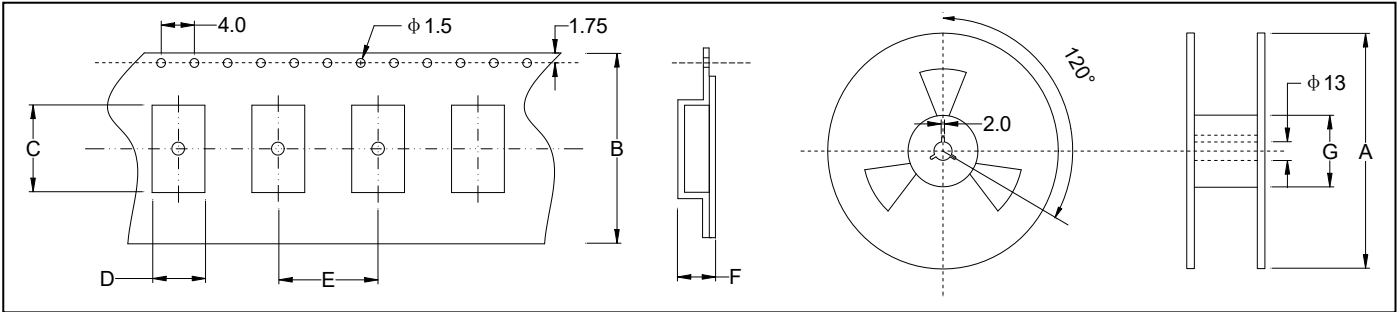

	A	B	C	D	E	F	G
OSC-SMD3225	178±2.0	8.0±0.3	3.55±0.10	2.80±0.10	4.0±0.1	1.4±0.1	60.5±1.0
2000 pcs per reel							

★ REFLOW SOLDERING PROFILE

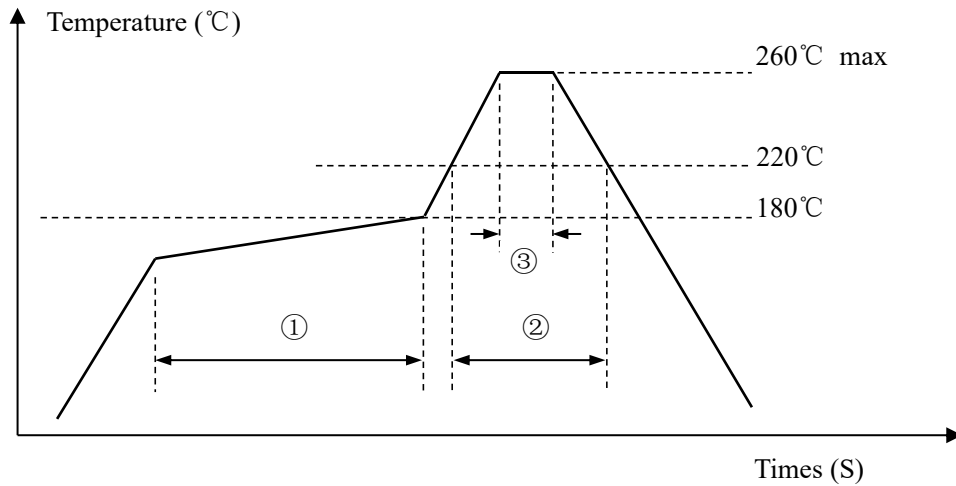

Pb free reflow A	①	Preheat	160~180°C	120sec. max
	②	Primary heat	220°C	60sec. max
	③	Peak	260°C	10sec. max.